

FD1771-01 Floppy Disk Formatter/Controller

FEATURES

- SOFT SECTOR FORMAT COMPATIBILITY
- AUTOMATIC TRACK SEEK WITH VERIFICATION
- READ MODE
 - Single/Multiple Sector Write with Automatic Sector Search or Entire Track Read
 - Selectable 128 Byte or Variable Length Sector
- WRITE MODE
 - Single/Multiple Sector Write with Automatic Sector Search
 - Entire Track Write for Diskette Formatting
- PROGRAMMABLE CONTROLS
 - Selectable Track-to-Track Stepping Time
 - Selectable Head Settling and Head Engage Times
 - Selectable Three Phase or Step and Direction and Head Positioning Motor Controls

- SYSTEM COMPATIBILITY
 - Double Buffering of Data 8-Bit Bi-Directional Bus for Data, Control and Status
 - DMA or Programmed Data Transfers
 - All Inputs and Outputs are TTL Compatible

• ~~INVERTED DATA BUS~~

APPLICATIONS

- FLOPPY DISK DRIVE INTERFACE
- SINGLE OR MULTIPLE DRIVE CONTROLLER/FORMATTER
- NEW MINI-FLOPPY CONTROLLER

GENERAL DESCRIPTION

The FD1771 is a MOS/LSI device that performs the functions of a Floppy Disk Controller/Formatter. The device is designed to be included in the disk drive electronics, and contains a flexible interface

JUNE, 1980

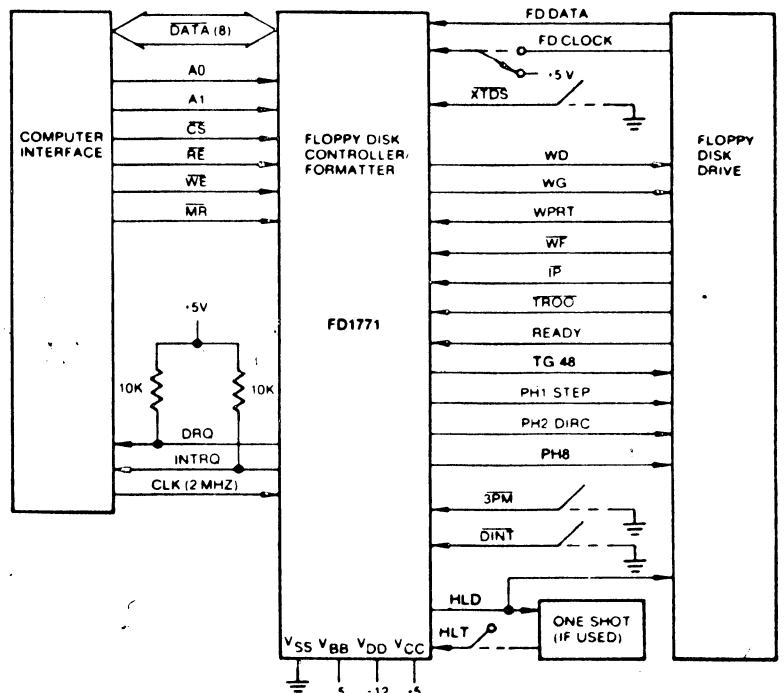
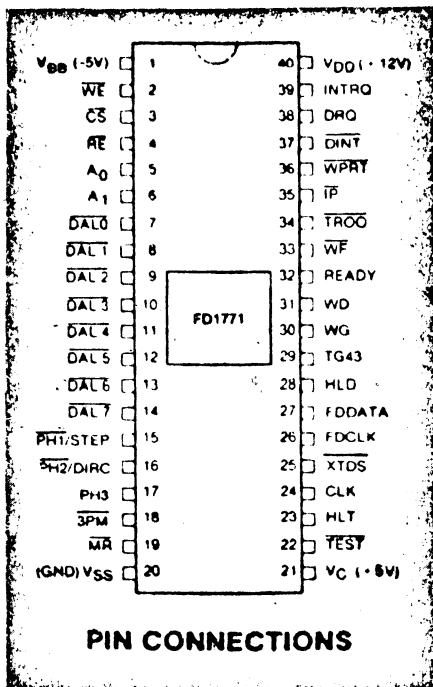

FD1771 SYSTEM BLOCK DIAGRAM

organization that accommodates the interface signals from most drive manufacturers. The FD1771 is compatible with the IBM 3740 data entry system format.

The processor interface consists of an 8-bit bi-directional bus for data, status, and control word

transfers. The FD1771 is set up to operate on a multiplexed bus with other bus-oriented devices.

The FD1771 is fabricated in N-channel Silicon Gate MOS technology and is TTL compatible on all inputs and outputs. The A and B suffixes are for ceramic and plastic packages, respectively.

PIN OUTS

Pin No.	Pin Name	Symbol	Function																									
1	Power Supplies	V_{BB}/NC	-5V																									
19	MASTER RESET	\overline{MR}	A logic low on this input resets the device and loads "03" into the command register. The Not Ready (Status bit 7) is reset during \overline{MR} ACTIVE. When \overline{MR} is brought to a logic high, a Restore Command is executed, regardless of the state of the Ready signal from the drive.																									
20		V_{SS}	Ground																									
21		V_{CC}	+5V																									
40		V_{DD}	+12V																									
Computer Interface																												
2	WRITE ENABLE	\overline{WE}	A logic low on this input gates data on the DAL into the selected register when \overline{CS} is low.																									
3	CHIP SELECT	\overline{CS}	A logic low on this input selects the chip and enables computer communication with the device.																									
4	READ ENABLE	\overline{RE}	A logic low on this input controls the placement of data from a selected register on the DAL when \overline{CS} is low.																									
5, 6	REGISTER SELECT LINES	A_0, A_1	These inputs select the register to receive/transfer data on the DAL lines under \overline{RE} and \overline{WE} control:																									
			<table border="0"> <tr> <td>A_1</td> <td>A_0</td> <td>\overline{RE}</td> <td>\overline{WE}</td> <td></td> </tr> <tr> <td>0</td> <td>0</td> <td>Status Register</td> <td>Command Register</td> <td></td> </tr> <tr> <td>0</td> <td>1</td> <td>Track Register</td> <td>Track Register</td> <td></td> </tr> <tr> <td>1</td> <td>0</td> <td>Sector Register</td> <td>Sector Register</td> <td></td> </tr> <tr> <td>1</td> <td>1</td> <td>Data Register</td> <td>Data Register</td> <td></td> </tr> </table>	A_1	A_0	\overline{RE}	\overline{WE}		0	0	Status Register	Command Register		0	1	Track Register	Track Register		1	0	Sector Register	Sector Register		1	1	Data Register	Data Register	
A_1	A_0	\overline{RE}	\overline{WE}																									
0	0	Status Register	Command Register																									
0	1	Track Register	Track Register																									
1	0	Sector Register	Sector Register																									
1	1	Data Register	Data Register																									
7-14	DATA ACCESS LINES	DAL0-DAL7	Eight bit <u>inverted</u> bidirectional bus used for transfer of data, control, and status. This bus is a receiver enabled by \overline{WE} or a transmitter enabled by \overline{RE} .																									
24	CLOCK	CLK	This input requires a free-running 2 MHz \pm 1% square wave clock for internal timing reference.																									
38	DATA REQUEST	DRQ	This open drain output indicates that the DR contains assembled data in Read operations, or the DR is empty in Write operations. This signal is reset when serviced by the computer through reading or loading the DR in Read or Write operation, respectively. Use 10K pull-up resistor to +5.																									
39	INTERRUPT REQUEST	INTRQ	This open drain output is set at the completion or termination of any operation and is reset when a new command is loaded into the command register. Use 10K pull-up resistor to +5.																									
Floppy Disk Interface:																												
15	Phase 1/Step	$\overline{PH1}/STEP$	If the $\overline{3PM}$ input is a logic low the three-phase motor control is selected and $\overline{PH1}$, $\overline{PH2}$, and $\overline{PH3}$ outputs																									

Pin No.	Pin Name	Symbol	Function
16	Phase 2/Direction	PH2/DIRC	form a one active low signal out of three. PH1 is active low after MR. If the 3PM input is a logic high the step and direction motor control is selected. The step output contains a 4 usec high signal for each step and the direction output is active high when stepping in; active low when stepping out.
17	Phase 3	PH3	
18	3-Phase Motor Select	3PM	
22	TEST	TEST	This input is used for testing purposes only and should be tied to +5V or left open by the user.
23	HEAD LOAD TIMING	HLT	The HLT input is sampled after 10 ms. When a logic high is sampled on the HLT input the head is assumed to be engaged.
25	EXTERNAL DATA SEPARATION	XTDS	A logic low on this input selects external data separation. A logic high or open selects the internal data separator.
26	FLOPPY DISK CLOCK (External Separation)	FDCLOCK	This input receives the externally separated clock when XTDS = 0. If XTDS = 1, this input should be tied to a logic high.
27	FLOPPY DISK DATA	FDDATA	This input receives the raw read disk data if XTDS=1, or the externally separated data if XTDS=0.
28	HEAD LOAD	HLD	The HLD output controls the loading of the Read-Write head against the media.
29	Track Greater than 43	TG43	This output informs the drive that the Read-Write head is positioned between tracks 44-76. This output is valid only during Read and Write commands.
30	WRITE GATE	WG	This output is made valid when writing is to be performed on the diskette.
31	WRITE DATA	WD	This output contains both clock and data bits of 500 ns duration.
32	Ready	READY	This input indicates disk readiness and is sampled for a logic high before Read or Write commands are performed. If Ready is low, the Read or Write operation is not performed and an interrupt is generated. A Seek operation is performed regardless of the state of Ready. The Ready input appears in inverted format as Status Register bit 7.
33	WRITE FAULT	WF	This input detects wiring faults indications from the drive. When WG=1 and WF goes low, the current Write command is terminated and the Write Fault status bit is set. The WF input should be made inactive (high) when WG becomes inactive.
34	TRACK 00	TR00	This input informs the FD1771 that the Read-Write head is positioned over Track 00 when a logic low.
35	INDEX PULSE	IP	Input, when low for a minimum of 10 usec, informs the FD1771 when an index mark is encountered on the diskette.
36	WRITE PROTECT	WPRT	This input is sampled whenever a Write command is received. A logic low terminates the command and sets the Write Protect status bit.
37	DISK INITIALIZATION	DINT	The input is sampled whenever a Write Track command is received. If DINT=0, the operation is terminated and the Write Protect status bit is set.

ORGANIZATION

The Floppy Disk Formatter block diagram is illustrated on page 4. The primary sections include the parallel processor interface and the Floppy Disk interface.

Data Shift Register: This 8-bit register assembles serial data from the Read Data input (FDDATA) during Read operations and transfers serial data to the Write Data output during Write operations.

Data Register: This 8-bit register is used as a holding register during Disk Read and Write operations. In Disk Read operations the assembled data byte is transferred in parallel to the Data Register from the Data Shift Register. In Disk Write operations information is transferred in parallel from the Data Register to the Data Shift Register.

When executing the Seek command, the Data Register holds the address of the desired Track position. This register can be loaded from the DAL and gated onto the DAL under processor control.

Track Register: This 8-bit register holds the track number of the current Read/Write head position. It is incremented by one every time the head is stepped in (towards track 76) and decremented by one when the head is stepped out (towards track 00). The contents of the register are compared with the recorded track number in the ID field during disk Read, Write, and Verify operations. The Track Register can be

loaded from or transferred to the DAL. This register should not be loaded when this device is busy.

Sector Register (SR): This 8-bit register holds the address of the desired sector position. The contents of the register are compared with the recorded sector number in the ID field during disk Read or Write operations. The Sector Register contents can be loaded from or transferred to the DAL. This register should not be loaded when the device is busy.

Command Register (CR): This 8-bit register holds the command presently being executed. This register should not be loaded when the device is busy unless the execution of the current command is to be overridden. This latter action results in an interrupt. The command register can be loaded from the DAL but not read onto the DAL.

Status Register (STR): This 8-bit register holds device Status information. The meaning of the Status bits are a function of the contents of the Command Register. This register can be read onto the DAL, but not loaded from the DAL.

CRC Logic: This logic is used to check or to generate the 16-bit Cyclic Redundancy Check (CRC). The polynomial is: $G(x) = x^{16} + x^{12} + x^5 + 1$.

The CRC includes all information starting with the address mark and up to the CRC characters. The CRC register is preset to ones prior to data being shifted through the circuit.

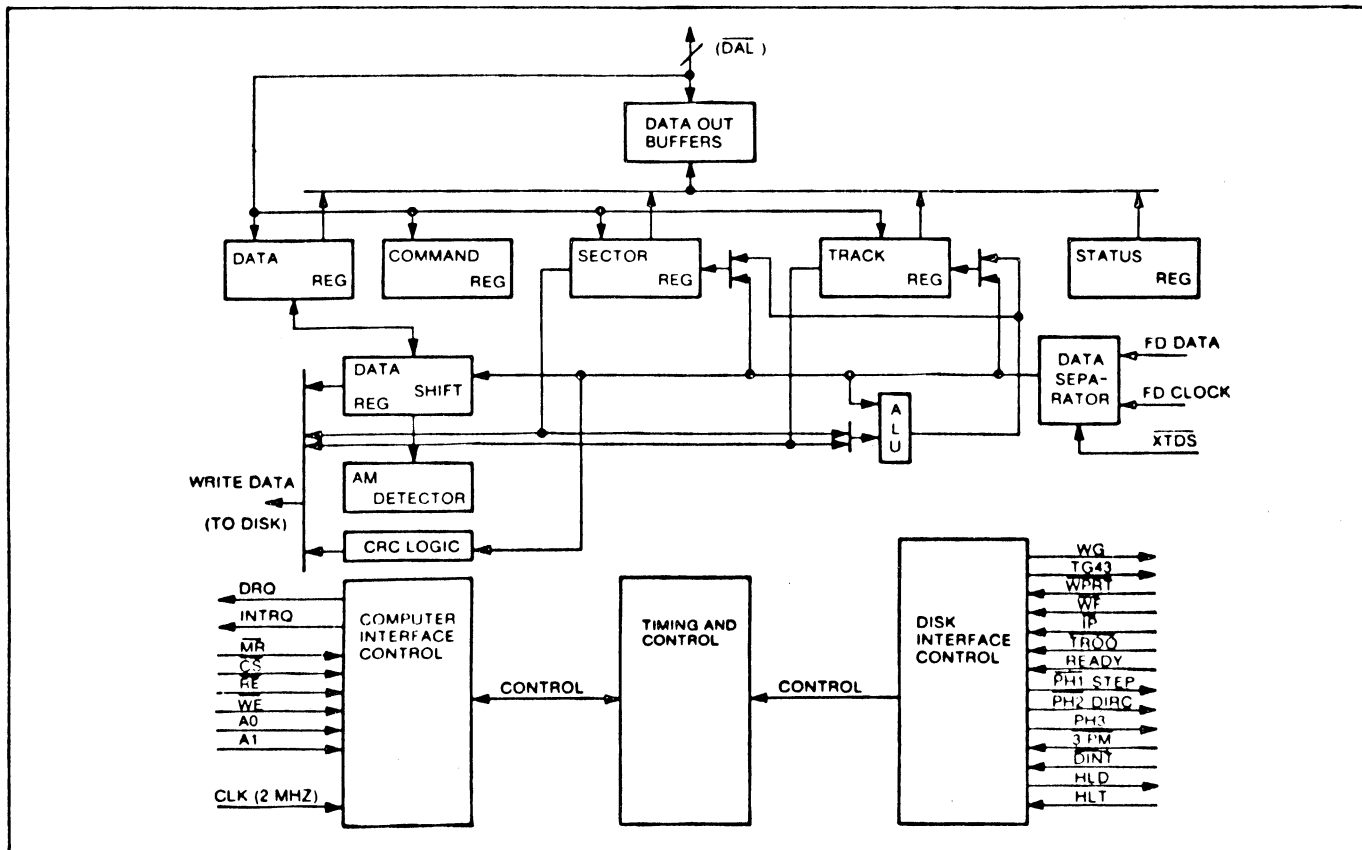

FD1771 BLOCK DIAGRAM

Arithmetic/Logic Unit (ALU): The ALU is a serial comparator, incremter, and decremter and is used for register modification and comparisons with the disk recorded ID field.

AM Detector: The Address Mark detector is used to detect ID, Data, and Index address marks during Read and Write operations.

Timing and Control: All computer and Floppy Disk Interface controls are generated through this logic. The internal device timing is generated from a 2.0 MHz external crystal clock.

PROCESSOR INTERFACE

The interface to the processor is accomplished through the eight Data Access Lines (DAL) and associated control signals. The DAL are used to transfer Data, Status, and Control words out of, or into the FD1771. The DAL are three-state buffers that are enabled as output drivers when Chip Select (CS) and Read Enable (RE) are active (low logic state) or act as input receivers when CS and Write Enable (WE) are active.

When transfer of data with the Floppy Disk Controller is required by the host processor, the device address is decoded and CS is made low. The least-significant address bits A1 and A0, combined with the signals RE during a Read operation or WE during a Write operation are interpreted as selecting the following registers:

A1-A0	READ (\overline{RE})	WRITE (\overline{WE})
0 0	Status Register	Command Register
0 1	Track Register	Track Register
1 0	Sector Register	Sector Register
1 1	Data Register	Data Register

During Direct Memory Access (DMA) types of data transfers between the Data Register of the FD1771 and the Processor, the Data Request (DRQ) output is used in Data Transfer control. This signal also appears as status bit 1 during Read and Write operations.

On Disk Read operations the Data Request is activated (set high) when an assembled serial input byte is transferred in parallel to the Data Register. This bit is cleared when the Data Register is read by the processor. If the Data Register is read after one or more characters are lost, by having new data transferred into the register prior to processor readout, the Lost Data bit is set in the Status Register. The Read operation continues until the end of sector is reached.

On Disk Write operations the Data Request is activated when the Data Register transfers its contents to the Data Shift Register, and requires a new data byte. It is reset when the Data Register is loaded with new data by the processor. If new data is not loaded

at the time the next serial byte is required by the Floppy Disk, a byte of zeroes is written on the diskette and the Lost Data bit is set in the Status Register.

The Lost Data bit and certain other bits in the Status Register will activate the interrupt request (INTRQ). The interrupt line is also activated with normal completion or abnormal termination of all controller operations. The INTRQ signal remains active until reset by reading the Status Register to the processor or by the loading of the Command Register. In addition, the INTRQ is generated if a Force Interrupt command condition is met.

FLOPPY DISK INTERFACE

The Floppy Disk interface consists of head positioning controls, write gate controls, and data transfers. A 2.0 MHz \pm 1% square wave clock is required at the CLK input for internal control timing (may be 1.0 MHz for mini floppy).

HEAD POSITIONING

Four commands cause positioning of the Read-Write head (see Command Section). The period of each positioning step is specified by the r field in bits 1 and 0 of the command word. After the last directional step, an additional 10 milliseconds of head settling time takes place. The four programmable stepping rates are tabulated below.

The rates (shown in Table 1) can be applied to a Three-Phase Motor or a Step-Direction Motor through the device interface. When the $\overline{3PM}$ input is connected to ground, the device operates with a three-phase motor control interface, with one active low signal per phase on the three output signals $\overline{PH1}$, $\overline{PH2}$, and PH3. The stepping sequence, when stepping in, is Phases 1-2-3-1, and when stepping out, Phases 1-3-2-1. Phase 1 is active low after Master Reset. Note: PH3 needs an inverter if used.

The Step-Direction Motor Control interface is activated by leaving input $\overline{3PM}$ open or connecting it to +5V. The Phase 1 pin $\overline{PH1}$ becomes a Step pulse of 4 microseconds width. The Phase 2 pin $\overline{PH2}$ becomes a direction control with a high voltage on this pin indicating a Step In, and a low voltage indicating a Step Out. The Direction output is valid a minimum of 24 μ s prior to the activation of the Step pulse.

When a Seek, Step or Restore command is executed, an optional verification of Read-Write head position can be performed by setting bit 2 in the command word to a logic 1. The verification operation begins at the end of the 10 millisecond settling time after the head is loaded against the media. The track number from the first encountered ID Field is compared against the contents of the Track Register. If the track numbers compare and the ID Field Cyclic Redundancy Check (CRC) is correct, the verify operation is complete. If track comparison is not

made but the CRC checks, an interrupt is generated, the Seek Error status (Bit 4) is set and the Busy status bit is reset.

Table 1. STEPPING RATES

r ₁	r ₀	1771-X1 CLK=2 MHz TEST=1	1771-X1 CLK=1 MHz TEST=1	1771 or -X1 CLK=2 MHz TEST=0	1771 or -X1 CLK=1 MHz TEST=0
0	0	6ms	12ms	Approx. 400us*	Approx. 800us*
0	1	6ms	12ms		
1	0	10ms	20ms		
1	1	20ms	40ms		

*For exact times consult WDC.

The Head Load (HLD) output controls the movement of the read/write head against the disk for data recording or retrieval. It is activated at the beginning of a Read, Write (E Flag On) or Verify operation, or a Seek or Step operation with the head load bit, h, a logic one remains activated until the third index pulse following the last operation which uses the read/write head. Reading or Writing does not occur until a minimum of 10 msec delay after the HLD signal is made active. If executing the type 2 commands with the E flag off, there is no 10 msec delay and the head is assumed to be engaged. The delay is determined by sampling of the Head Load Timing (HLT) input after 10 msec. A high state input, generated from the Head Load output transition and delayed externally, identifies engagement of the head against the disk. In the Seek and Step commands, the head is loaded at the start of the command execution when the h bit is a logic one. In a verify command the head is loaded after stepping to the destination track on the disk whenever the h bit is a logic zero.

DISK READ OPERATION

The 2.0 MHz external clock provided to the device is internally divided by 4 to form the 500 kHz clock rate for data transfer. When reading data from a diskette this divider is synchronized to transitions of the Read Data (FDDATA) input. When a transition does not occur on the 500 kHz clock active state, the clock divider circuit injects a clock to maintain a continuous 500 kHz data clock. The 500 kHz data clock is further divided by 2 internally to separate the clock and information bits. The divider is phased to the information by the detection of the address mark.

In the internal data read and separation mode the Read Data input toggles from one state to the opposite state for each logic one bit of clock or information. This signal can be derived from the amplified, differentiated, and sliced Read Head signal, or by the output of a flip-flop toggling on the Read Data pulses. This input is sampled by the 2 MHz clock to detect transitions.

The chip can also operate on externally separated data, as supplied by methods such as Phase Lock loop, One Shots, or variable frequency oscillators. This is accomplished by grounding the External Data Separator (XTDS) INPUT. When the Read Data input makes a high-to-low transition, the information input to the FDDATA line is clocked into the Data Shift Register. The assembled 8-bit data from the Data Shift Register are then transferred to the Data Register.

The normal sector length for read or Write operations with the IBM 3740 format is 128 bytes. This format or binary multiples of 128 bytes will be adopted by setting a logic 1 in Bit 3 of the Read and Write commands. Additionally, a variable sector length feature is provided which allows an indicator recorded in the ID Field to control the length of the sector. Variable sector lengths can be read or written in Read or Write commands, respectively, by setting a logic 0 in Bit 3 of the command word. The sector length indicator specifies the number of 16 byte groups or 16 x N, where N is equal to 1 to 256 groups. An indicator of all zeroes is interpreted as 256 sixteen byte groups.

DISK WRITE OPERATION

After data is loaded from the processor into the Data Register, and is transferred to the Data Shift Register, data will be shifted serially through the Write Data (WD) output. Interlaced with each bit of data is a positive clock pulse of 0.5 μsec duration. This signal may be used to externally toggle a flip-flop to control the direction of Write Current flow.

When writing is to take place on the diskette the Write Gate (WG) output is activated, allowing current to flow into the Read/Write head. As a precaution to erroneous writing, the first data byte must be loaded into the Data Register in response to a Data Request from the FD1771 before the Write Gate signal can be activated.

Writing is inhibited when the Write Protect input is a logic low, in which case any Write command is immediately terminated, an interrupt is generated and the Write Protect status bit is set. The Write Fault input, when activated, signifies a writing fault condition detected in disk drive electronics such as failure to detect write current flow when the Write Gate is activated. On detection of this fault the FD1771 terminates the current command, and sets the Write Fault bit (bit 5) in the Status Word. The Write Fault input should be made inactive when the Write Gate output becomes inactive.

Whenever a Read or Write command is received the FD1771 samples the READY input. If this input is logic low the command is not executed and an interrupt is generated. The Seek or Step commands are performed regardless of the state of the READY input.

COMMAND DESCRIPTION

The FD1771 will accept and execute eleven commands. Command words should only be loaded in the Command Register when the Busy status bit is off (status bit 0). The one exception is the Force Interrupt command. Whenever a command is being executed, the Busy status bit is set. When a command is completed, an interrupt is generated and the Busy status bit is reset. The Status Register indicates whether the completed command encountered an error or was fault-free. For ease of discussion, commands are divided into four types. Commands and types are summarized in Table 2.

TYPE 1 COMMANDS

The Type 1 Commands include the RESTORE, SEEK, STEP, STEP-IN, and STEP-OUT commands. Each of the Type 1 Commands contain a rate field (r_0r_1), which determines the stepping motor rate as defined in Table 1, page 4.

The Type 1 Commands contain a head load flag (h) which determines if the head is to be loaded at the

Table 2. COMMAND SUMMARY

TYPE	COMMAND	BITS							
		7	6	5	4	3	2	1	0
I	Restore	0	0	0	0	h	V	r_1	r_0
I	Seek	0	0	0	1	h	V	r_1	r_0
I	Step	0	0	1	u	h	V	r_1	r_0
I	Step In	0	1	0	u	h	V	r_1	r_0
I	Step Out	0	1	1	u	h	V	r_1	r_0
II	Read Command	1	0	0	m	b	E	0	0
II	Write Command	1	0	1	m	b	E	a_1a_0	
III	Read Address	1	1	0	0	0	E	0	0
III	Read Track	1	1	1	0	0	1	0	\bar{s}
III	Write Track	1	1	1	1	0	1	0	0
IV	Force Interrupt	1	1	0	1	l_3	l_2	l_1	l_4

Note: Bits shown in TRUE form.

Table 3. FLAG SUMMARY

TYPE I
<u>h = Head Load flag (Bit 3)</u> h = 1, Load head at beginning h = 0, Do not load head at beginning
<u>V = Verify flag (Bit 2)</u> V = 1, Verify on last track V = 0, No verify
<u>r_1r_0 = Stepping motor rate (Bits 1-0)</u> Refer to Table 1 for rate summary
<u>u = Update flag (Bit 4)</u> u = 1, Update Track register u = 0, No update

Table 4. FLAG SUMMARY

TYPE II
<u>m = Multiple Record flag (Bit 4)</u> m=0, Single Record m=1, Multiple Records
<u>b = Block length flag (Bit 3)</u> b=1, IBM format (128 to 1024 bytes) b=0, Non-IBM format (16 to 4096 bytes)
<u>a_1a_0 = Data Address Mark (Bits 1-0)</u> a_1a_0 = 00, FB (Data Mark) a_1a_0 = 01, FA (User defined) a_1a_0 = 10, F9 (User defined) a_1a_0 = 11, F8 (Deleted Data Mark)

Table 5. FLAG SUMMARY

TYPE III
<u>s = Synchronize flag (Bit 0)</u> \bar{s} =0, Synchronize to AM (Address Mark) \bar{s} =1, Do Not Synchronize to AM
TYPE IV
<u>l_i = Interrupt Condition flags (Bits 3-0)</u> l_0 =1, Not Ready to Ready Transition l_1 =1, Ready to Not Ready Transition l_2 =1, Index Pulse l_3 =1, Immediate interrupt
<u>E = Enable HLD and 10 msec Delay</u> E=1, Enable HLD, HLT and 10 msec Delay E=0, Head is assumed Engaged and there is no 10 msec Delay

beginning of the command. If h=1, the head is loaded at the beginning of the command (HLD output is made active). If h=0, HLD is deactivated. Once the head is loaded, the head will remain engaged until the FD1771 receives a command that specifically disengages the head. If the FD1771 does not receive any commands after two revolutions of the disk, the head will be automatically disengaged (HLD made inactive). The Head Load Timing Input is sampled after a 10 ms delay, when reading or writing on the disk is to occur.

The Type 1 Commands also contain a verification (V) flag which determines if a verification operation is to take place on the destination track. If V=1, a verification is performed; if V=0, no verification is performed.

During verification, the head is loaded and after an internal 10 ms delay, the HLT input is sampled. When

HLT is active (logic true), the first encountered ID field is read off the disk. The track address of the ID Field is then compared to the Track Register; if there is a match and a valid ID CRC, the verification is complete, an interrupt is generated and the BUSY status bit is reset. If there is not a match but there is valid ID CRC, an interrupt is generated, the Seek Error status bit (Status Bit 4) is set and the BUSY status bit is reset. If there is a match but not a valid CRC, the CRC error status bit is set (Status Bit 3), and the next encountered ID Field is read from the disk for the verification operation. If an ID Field with a valid CRC cannot be found after two revolutions of the disk, the FD1771 terminates the operation and sends an interrupt (INTRQ).

The STEP, STEP-IN, and STEP-OUT commands contain an UPDATE flag (U). When U=1, the track register is updated by one for each step. When U=0, the track register is not updated.

RESTORE (SEEK TRACK 0)

Upon receipt of this command the Track 00 ($\overline{TR00}$) input is sampled. If $\overline{TR00}$ is active low indicating the Read-Write head is positioned over track 0, the Track Register is loaded with zeroes and an interrupt is generated. If $\overline{TR00}$ is not active low, stepping pulses (pins 15 to 17) at a rate specified by the r_{10} field are issued until the $\overline{TR00}$ input is activated. At this time the TR is loaded with zeroes and an interrupt is generated. If the $\overline{TR00}$ input does not go active low after 255 stepping pulses, the FD1771 terminates operation, interrupts, and sets the Seek error status bit. Note that the RESTORE command is executed when \overline{MR} goes from an active to an inactive state. A verification operation takes place if the V flag is set. The h bit allows the head to be loaded at the start of command.

SEEK

This command assumes that the Track Register contains the track number of the current position of the

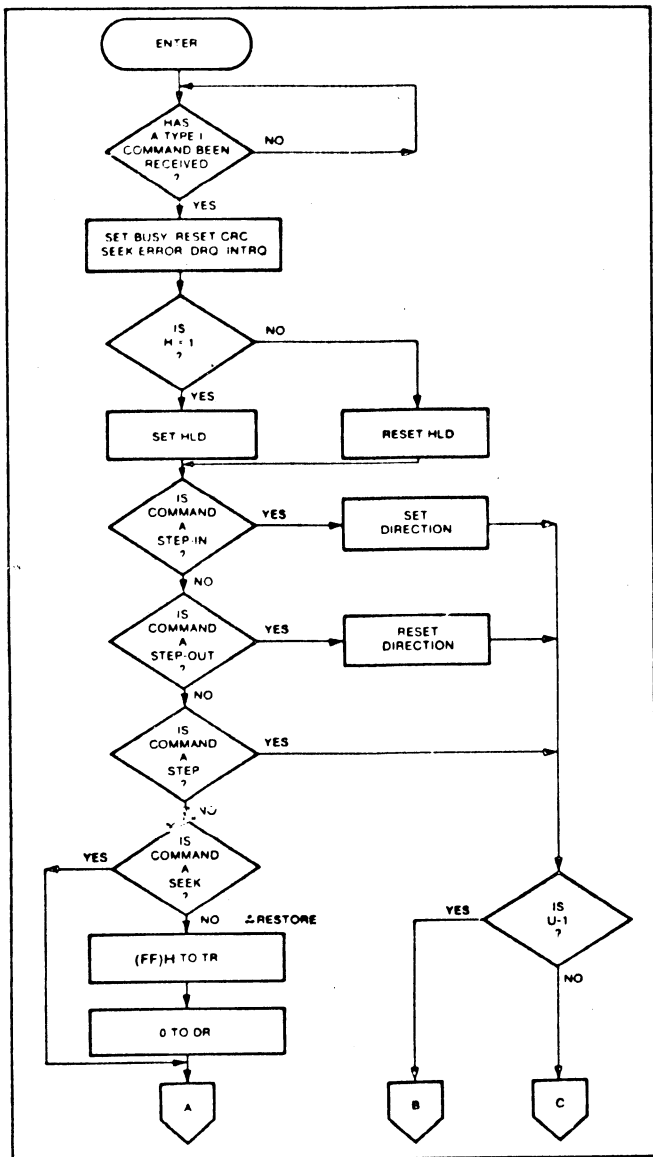

TYPE I COMMAND FLOW

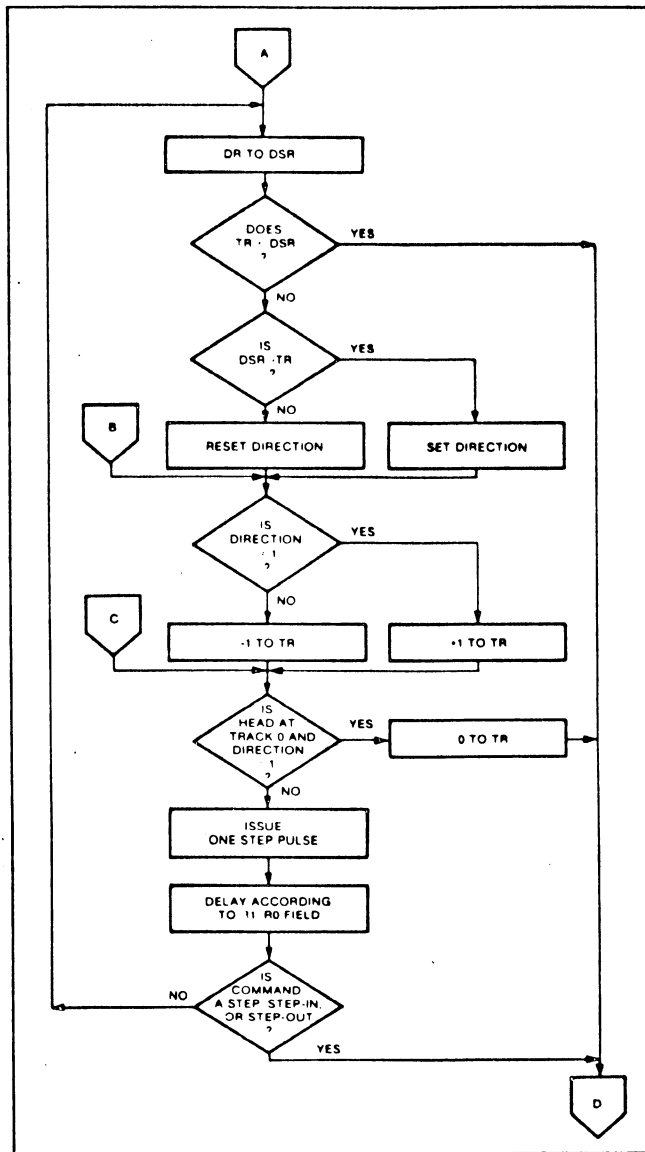

TYPE I COMMAND FLOW

Read-Write head and the Data Register contains the desired track number. The FD1771 will update the Track register and issue stepping pulses in the appropriate direction until the contents of the Track register are equal to the contents of the data register (the desired track location). A verification operation takes place if the V flag is on. The h bit allows the head to be loaded at the start of the command. An interrupt is generated at the completion of the command.

STEP

Upon receipt of this command, the FD1771 issues one stepping pulse to the disk drive. The stepping motor direction is the same as in the previous step command. After a delay determined by the r_{1r0} field, a verification takes place if the V flag is on. If the u flag is on, the TR is updated. The h bit allows the head to be loaded at the start of the command. An

interrupt is generated at the completion of the command.

STEP-IN

Upon receipt of this command, the FD1771 issues one stepping pulse in the direction towards track 76. If the u flag is on, the Track Register is incremented by one. After a delay determined by the r_{1r0} field, a verification takes place if the V flag is on. The h bit allows the head to be loaded at the start of the command. An interrupt is generated at the completion of the command.

STEP-OUT

Upon receipt of this command, the FD1771 issues one stepping pulse in the direction towards track 0. If the u flag is on, the TR is decremented by one. After a delay determined by the r_{1r0} field, a verification takes place if the V flag is on. The h bit allows the head to be loaded at the start of the command. An interrupt is generated at the completion of the command.

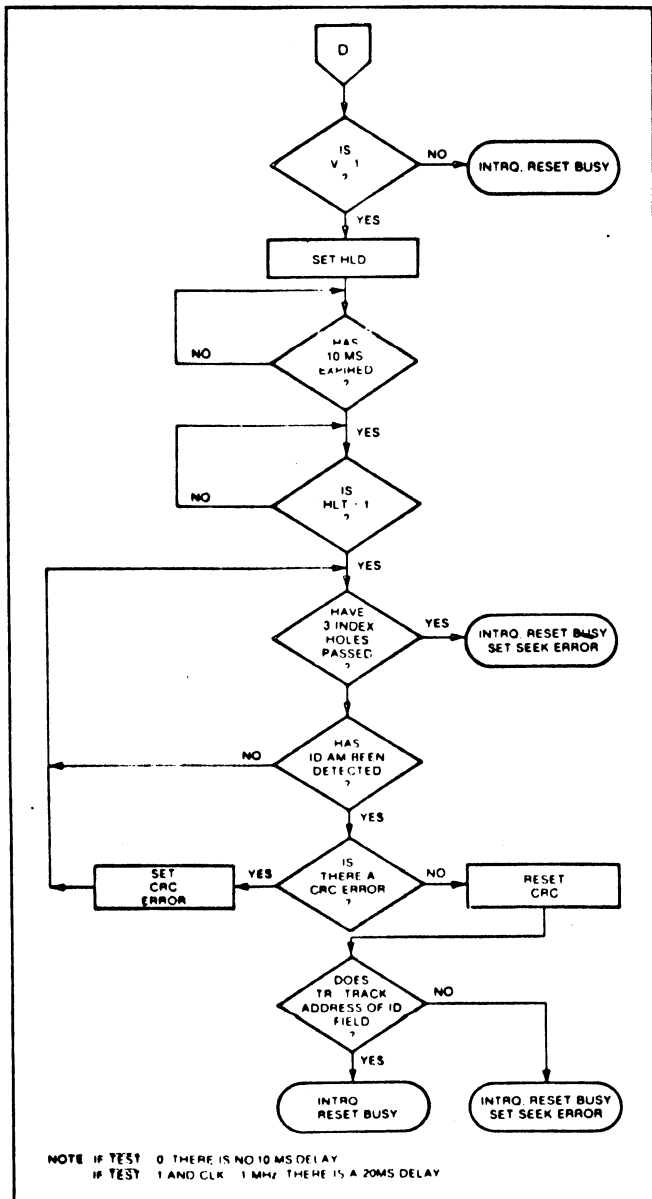

TYPE I COMMAND FLOW

TYPE II COMMANDS

The Type II Commands include the Read Sector(s) and Write Sector(s) commands. Prior to loading the Type II command into the COMMAND REGISTER, the computer must load the Sector Register with the desired sector number. Upon receipt of the Type II command, the Busy status bit is set. If the E flag=1 (this is the normal case), HLD is made active and HLT is sampled after a 10 msec delay. If the E flag is 0, the head is assumed to be engaged and there is no 10 msec delay. The ID field and the Data Field format are shown below.

When an ID field is located on the disk, the FD1771 compares the track number of the ID field with the Track Register. If there is not a match, the next encountered ID field is read and a comparison is again made. If there was a match, the Sector Number of the ID field is compared with the Sector Register. If there is not a Sector match, the next encountered ID field is read off the disk and comparisons again made. If the ID field CRC is correct, the data field is then located and will be either written into, or read from depending on the command. The FD1771 must find an ID field with a track number, Sector number, and CRC within two revolutions of the disk; otherwise, the Record Not Found status bit is set (Status bit 3) and the command is terminated with an interrupt.

Each of the Type II Commands contain a (b) flag which in conjunction with the sector length field contents of the ID determines the length (number of characters) of the Data field.

For IBM 3740 compatibility, the b flag should equal 1. The numbers of bytes in the data field (sector) is then 128×2^n where $n = 0, 1, 2, 3$.

GAP	ID AM	TRACK NUMBER	ZERO	SECTOR NUMBER	SECTOR LENGTH	CRC 1	CRC 2	GAP	DATA AM	DATA FIELD	CRC 1	CRC 2
ID FIELD									DATA FIELD			

IDAM = ID Address Mark — DATA = (FE)₁₆ CLK = (C7)₁₆

Data AM = Data Address Mark — DATA = (F8, F9, FA, or FB). CLK = (C7)₁₆

For b = 1

Sector Length Field (Hex)	Number of Bytes in Sector (Decimal)
00	128
01	256
02	512
03	1024

When the b flag equals zero, the sector length field (n) multiplied by 16 determines the number of bytes in the sector or data field as shown below.

For b = 0

Sector Length Field (Hex)	Number of Bytes in Sector (Decimal)
01	16
02	32
03	48
04	64
•	•
•	•
•	•
FF	4080
00	4096

Each of the Type II commands also contain a (m) flag which determines if the multiple records (sectors) are to be read or written, depending upon the command. If m=0 a single sector is read or written and an interrupt is generated at the completion of the command. If m=1, multiple records are read or written with the sector register internally updated so that an address verification can occur on the next record. The FD1771 will continue to read or write multiple records and update the sector register until the sector register exceeds the number of sectors on the track or until the Force Interrupt command is loaded into the command register, which terminated the command and generates an interrupt.

READ COMMAND

Upon receipt of the Read command, the head is loaded, the BUSY status bit set, and when an ID field is encountered that has the correct track number, correct sector number, and correct CRC, the data field is presented to the computer. The Data Address Mark of the data field must be found within 28 bytes of the correct field; if not, the Record Not Found status bit is set and the operation is terminated. When

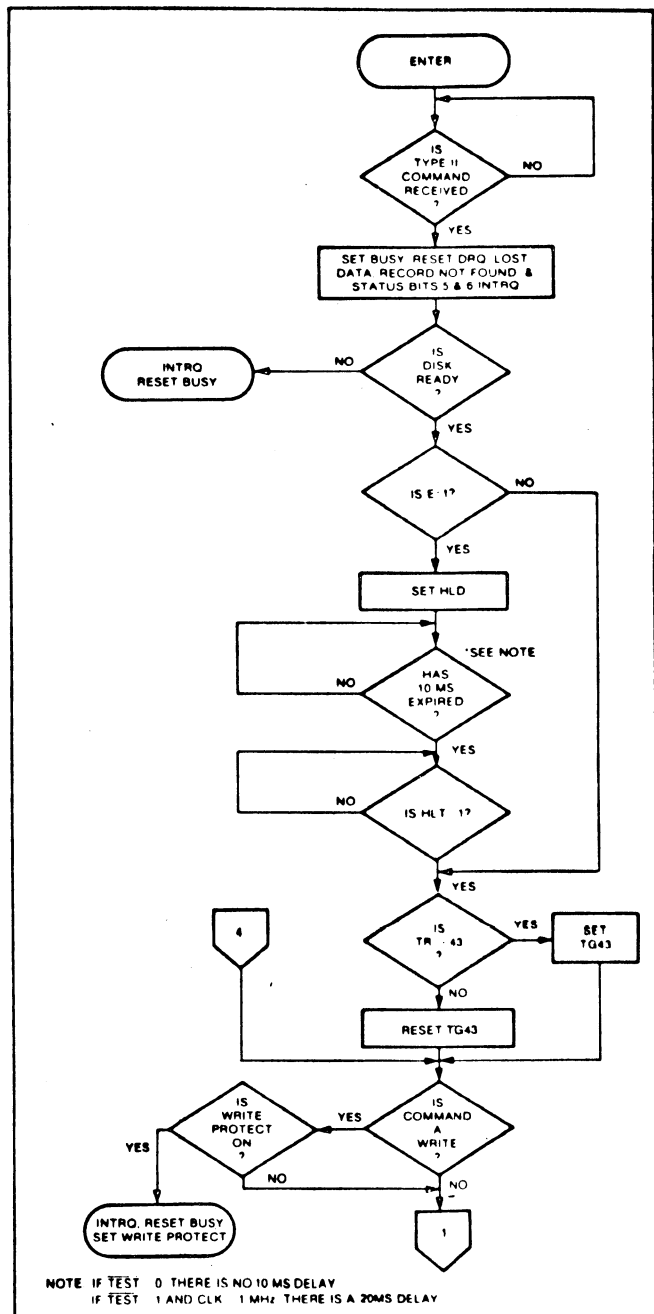

TYPE II COMMAND FLOW

the first character or byte of the data field has been shifted through the DSR, it is transferred to the DR, and DRQ is generated. When the next byte is accumulated in the DSR, it is transferred to the DR and another DRQ is generated. If the computer has not read the previous contents of the DR before a new character is transferred that character is lost and the

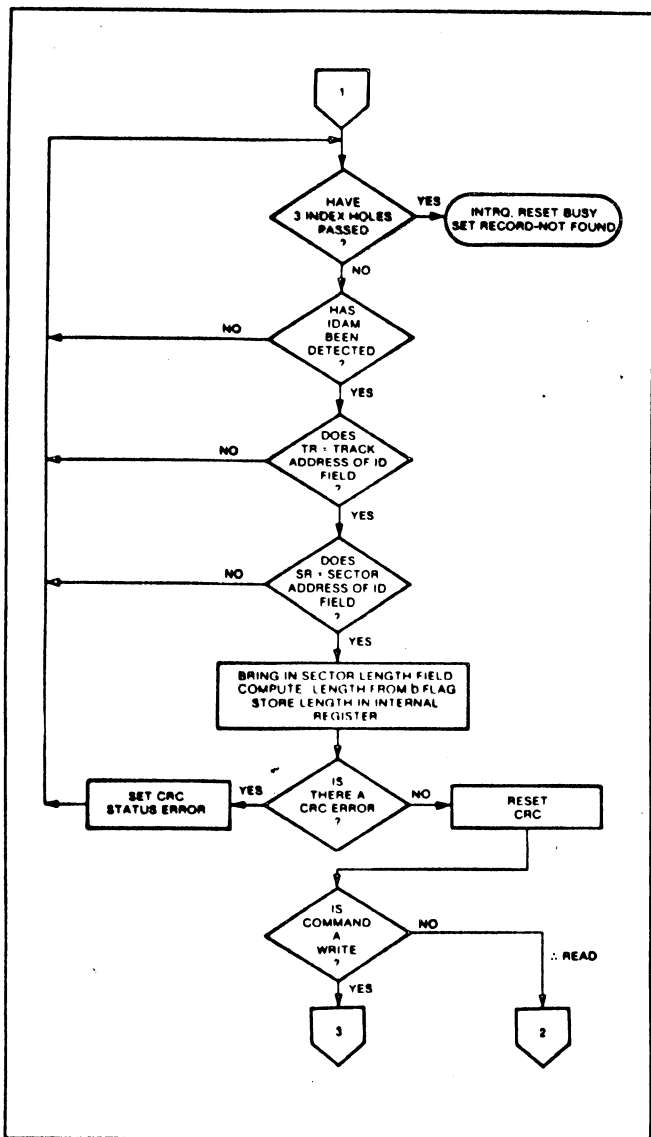

TYPE II COMMAND FLOW

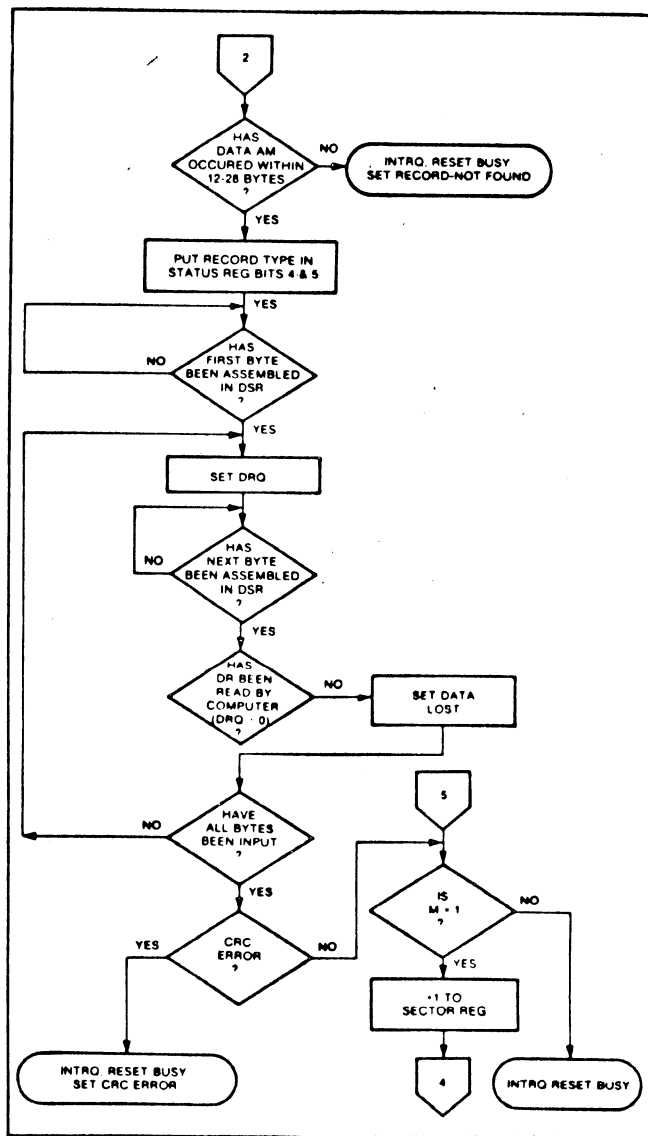

TYPE II COMMAND FLOW

Lost Data status bit is set. This sequence continues until the complete data field has been input to the computer. If there is a CRC error at the end of the data field, the CRC error status bit is set, and the command is terminated (even if it is a multiple record command).

At the end of the Read operation, the type of Data Address Mark encountered in the data field is recorded in the Status Register (Bits 5 and 6) as shown below.

Status Bit 5	Status Bit 6	Data AM (Hex)
0	0	FB
0	1	FA
1	0	F9
1	1	F8

WRITE COMMAND

Upon receipt of the Write command, the head is loaded (HLD active) and the BUSY status bit is set. When an ID field is encountered that has the correct track number, correct sector number, and correct CRC, a DRQ is generated. The FD1771 counts off 11 bytes from the CRC field and the Write Gate (WG) output is made active if the DRQ is serviced (i.e., the DR has been loaded by the computer). If DRQ has not been serviced, the command is terminated and the Lost Data status bit is set. If the DRQ has been serviced, the WG is made active and six bytes of zeros are then written on the disk. At this time the Data Address Mark is then written on the disk as determined by the $a_1 a_0$ field of the command as shown on next page.

The FD1771 then writes the data field and generates DRQs to the computer. If the DRQ is not serviced in

a ₁	a ₀	Data Mark (Hex)	Clock Mark (Hex)
0	0	FB	C7
0	1	FA	C7
1	0	F9	C7
1	1	F8	C7

time for continuous writing the Lost Data status bit is set and a byte of zeros is written on the disk. The command is not terminated. After the last data byte has been written on the disk, the two-byte CRC is computed internally and written on the disk followed by one byte gap of logic ones. The WG output is then deactivated.

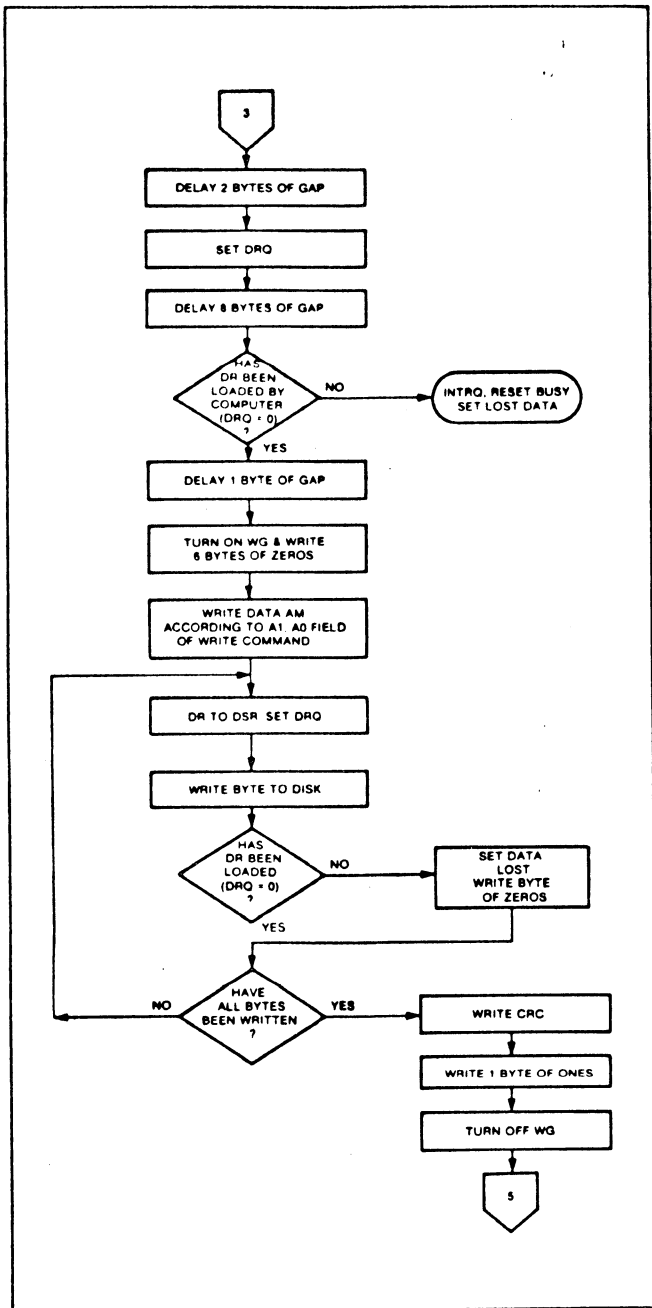

TYPE II COMMAND FLOW

TYPE III COMMANDS

READ Address

Upon receipt of the Read Address command, the head is loaded and the BUSY Status bit is set. The next encountered ID field is then read in from the disk, and the six data bytes of the ID field are assembled and transferred to the DR, and a DRQ is generated for each byte. The six bytes of the ID field are shown below.

TRACK ADDR	SIDE NUMBER	SECTOR ADDRESS	SECTOR LENGTH	CRC 1	CRC 2
1	2	3	4	5	6

Although the CRC characters are transferred to the computer, the FD1771 checks for validity and the CRC error status bit is set if there is a CRC error. The Sector Address of the ID field is written into the Sector Register. At the end of the operation an interrupt is generated and the BUSY Status is reset.

READ TRACK

Upon receipt of the Read Track command, the head is loaded and the BUSY status bit is set. Reading starts with the leading edge of the first encountered index mark and continues until the next index pulse. As each byte is assembled it is transferred to the Data Register and the Data Request is generated for each byte. No CRC checking is performed. Gaps are included in the input data stream. If bit 0(S) of the command is a 0, the accumulation of bytes is synchronized to each Address Mark encountered. Upon completion of the command, the interrupt is activated.

WRITE TRACK

Upon receipt of the Write Track command, the head is loaded and the BUSY status bit is set. Writing starts with the leading edge of the first encountered index pulse and continues until the next index pulse, at which time the interrupt is activated. The Data Request is activated immediately upon receiving the command, but writing will not start until after the first byte has been loaded into the Data Register. If the DR has not been loaded by the time the index pulse is encountered the operation is terminated making the device Not Busy, the Lost Data status bit is set, and the Interrupt is activated. If a byte is not present in the DR when needed, a byte of zeros is substituted. Address Marks and CRC characters are written on the disk by detecting certain data byte patterns in the outgoing data stream as shown in the table below. The CRC generator is initialized when any data byte from F8 to FE is about to be transferred from the DR to the DSR.

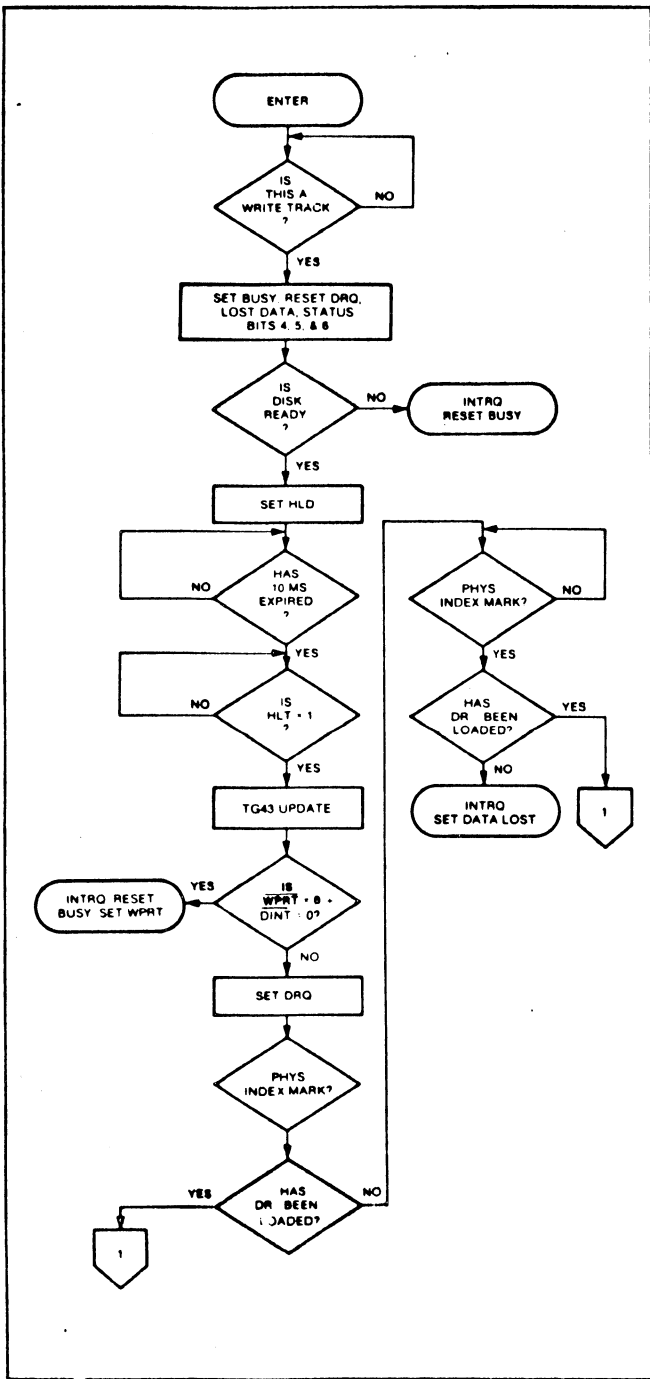

TYPE III COMMAND WRITE TRACK

CONTROL BYTES FOR INITIALIZATION

DATA PATTERN (HEX)	INTERPRETATION	CLOCK MARK (HEX)
F7	Write CRC Character	FF
F8	Data Address Mark <i>(deleted data)</i>	C7
F9	Data Address Mark	C7
FA	Data Address Mark	C7
FB	Data Address Mark	C7
FC	Index Address Mark	D7
FD	Spare	
FE	ID Address Mark	C7

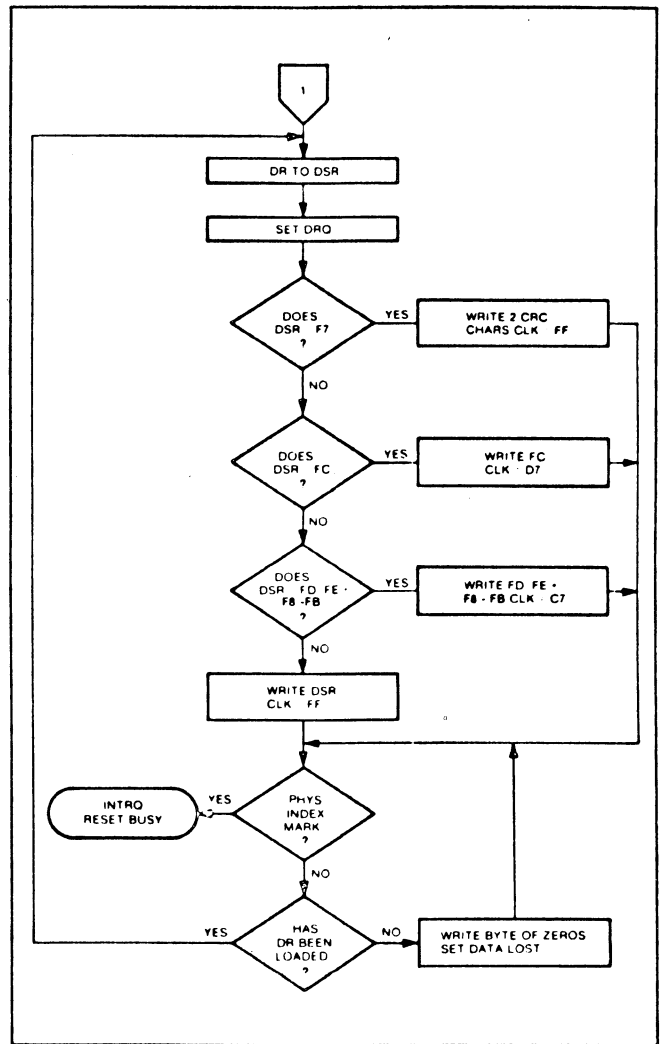

TYPE III COMMAND WRITE TRACK

The Write Track Command will not execute if the DINT input is grounded; instead, the Write Protect status bit is set and the interrupt is activated. Note that one F7 pattern generates two CRC characters.

TYPE IV COMMAND

Force Interrupt

This command can be loaded into the command register at any time. If there is a current command under execution (BUSY status bit set), the command will be terminated and an interrupt will be generated when the condition specified in the I₀ through I₃ field is detected. The interrupt conditions are shown below:

- I₀ = Not-Ready-To-Ready Transition
- I₁ = Ready-To-Not-Ready Transition
- I₂ = Every Index Pulse
- I₃ = Immediate Interrupt (Requires reset, see Note)

NOTE: If I₀ - I₃ = 0, there is no interrupt generated but the current command is terminated and busy is reset. This is the only command that will clear the immediate interrupt.

STATUS DESCRIPTION

Upon receipt of any command, except the Force Interrupt command, the Busy Status bit is set and the rest of the status bits are updated or cleared for the new command. If the Force Interrupt Command is received when there is a current command under execution, the Busy status bit is reset, and the rest of the status bits are unchanged. If the Force Interrupt command is received when there is not a current command under execution, the Busy Status bit is

reset and the rest of the status bits are updated or cleared. In this case, Status reflects the Type I commands.

The format of the Status Register is shown below.

(BITS)							
7	6	5	4	3	2	1	0
S7	S6	S5	S4	S3	S2	S1	S0

Status varies according to the type of command executed as shown in Table 6.

Table 6. STATUS REGISTER SUMMARY

BIT	ALL TYPE I COMMANDS	READ ADDRESS	READ	READ TRACK	WRITE	WRITE TRACK
S7	NOT READY	NOT READY	NOT READY	NOT READY	NOT READY	NOT READY
S6	WRITE PROTECT	0	RECORD TYPE	0	WRITE PROTECT	WRITE PROTECT
S5	HEAD ENGAGED	0	RECORD TYPE	0	WRITE FAULT	WRITE FAULT
S4	SEEK ERROR	ID NOT FOUND	RECORD NOT FOUND	0	RECORD NOT FOUND	0
S3	CRC ERROR	CRC ERROR	CRC ERROR	0	CRC ERROR	0
S2	TRACK 0	LOST DATA	LOST DATA	LOST DATA	LOST DATA	LOST DATA
S1	INDEX	DRQ	DRQ	DRQ	DRQ	DRQ
S0	BUSY	BUSY	BUSY	BUSY	BUSY	BUSY

STATUS FOR TYPE I COMMANDS

BIT	NAME	MEANING
S7	NOT READY	This bit when set indicates the drive is not ready. When reset it indicates that the drive is ready. This bit is an inverted copy of the READY input and logically "ored" with MR.
S6	PROTECTED	When set, indicates Write Protect is activated. This bit is an inverted copy of WRPT input.
S5	HEAD LOADED	When set, it indicates the head is loaded and engaged. This bit is a logical "and" of HLD and HLT signals.
S4	SEEK ERROR	When set, the desired track was not verified. This bit is reset to 0 when updated.
S3	CRC ERROR	When set, there was one or more CRC errors encountered on an unsuccessful track verification operation. This bit is reset to 0 when updated.
S2	TRACK 00	When set, indicates Read-Write head is positioned to Track 0. This bit is an inverted copy of the TR00 input.
S1	INDEX	When set, indicates index mark detected from drive. This bit is an inverted copy of the IP input.
S0	BUSY	When set, command is in progress. When reset, no command is in progress.

STATUS BITS FOR TYPE II AND III COMMANDS

BIT	NAME	MEANING
S7	NOT READY	This bit when set indicates the drive is not ready. When reset, it indicates that the drive is ready. This bit is an inverted copy of the READY input and "ored" with MR. The TYPE II and III Commands will not execute unless the drive is ready.
S6	RECORD TYPE/WRITE PROTECT	On Read Record: It indicates the MSB of record-type code from data field address mark. On Read Track: Not Used. On any Write Track: It indicates a Write Protect. This bit is reset when updated.
S5	RECORD TYPE/WRITE FAULT	On Read Record: It indicates the LSB of record-type code from data field address mark. On Read Track: Not Used. On any Write Track: It indicates a Write Fault. This bit is reset when updated.
S4	RECORD NOT FOUND	When set, it indicates that the desired track and sector were not found. This bit is reset when updated.
S3	CRC ERROR	If S4 is set, an error is found in one or more ID fields; otherwise it indicates error in data field. This bit is reset when updated.
S2	LOST DATA	When set, it indicates the computer did not respond to DRQ in one byte time. This bit is reset to zero when updated.
S1	DATA REQUEST	This bit is a copy of the DRQ output. When set, it indicates the DR is full on a Read operation or the DR is empty on a Write operation. This bit is reset to zero when updated.
S0	BUSY	When set, command is under execution. When reset, no command is under execution.

FORMATTING THE DISK (Refer to section on Type III Commands for flow diagrams.)

Formatting the disk is a relatively simple task when operating programmed I/O or when operating under DMA control with a large amount of memory. When operating under DMA with limited amount of memory, formatting is a more difficult task. This is because gaps as well as data must be provided at the computer interface.

Formatting the disk is accomplished by positioning the R/W head over the desired track number and issuing the Write Track command. Upon receipt of the Write Track command, the FD1771 raises the Data Request signal. At this point in time, the user loads the Data Register with desired data to be written on the disk. For every byte of information to be written on the disk, a Data Request is generated. This sequence continues from one index mark to the next index mark. Normally, whatever data pattern appears in the Data Register is written on the disk with a clock mark of (FF)₁₆. However, if the FD1771 detects a data pattern on F7 through FE in the Data

Register, this is interpreted as data address marks with missing clocks or CRC generation. For instance, an FE pattern will be interpreted as an ID address mark (DATA-FE, CLK-C7) and the CRC will be initialized. An F7 pattern will generate two CRC characters. As a consequence, the patterns F7 through FE must not appear in the gaps, data fields, or ID fields. Also, CRCs must be generated by an F7 pattern.

Disks may be formatted in IBM 3740 formats with sector lengths of 128,256,512, or 1024 bytes, or may be formatted in non-IBM format with sector lengths of 16 to 4096 bytes in 16-byte increments. IBM 3740 at the present time only defines two formats. One format with 128 bytes/sector and the other with 256 bytes/sector. The next section deals with the IBM 3740 format with 128 bytes/sector followed by a section of non-IBM formats.

IBM 3740 Formats — 128 Bytes/Sector

The IBM format with 128 bytes/sector is depicted in the Track Format figure on the following page. In order to create this format, the user must issue the

Write Track command, and load the data register with the following values. For every byte to be written, there is one data request.

Number of Bytes	Hex Value of Byte Written
40	00 or FF
6	00
1	FC (Index Mark)
* 26	00 or FF
6	00
1	FE (ID Address Mark)
1	Track Number (0 through 4C)
1	00 (<i>side #</i>)
1	Sector Number (1 through 1A)
1	00 (<i>sector length</i>)
1	F7 (two CRCs written)
11	00 or FF
6	00
1	FB (Data Address Mark)
128	Data (IBM uses E5)
1	F7 (two CRCs written)
27	00 or FF
247**	00 or FF

5156 Bytes per Track

*Write bracketed field 26 times.

**Continue writing until FD1771 interrupts out. Approximately 247 bytes.

Non-IBM Formats

Non-IBM formats are very similar to the IBM formats except a different algorithm is used to ascertain the sector length from the sector length byte in the ID field. This permits a wide range of sector lengths from 16 to 4096 bytes. Refer to Section V, Type II commands with b flag equal to zero. Note that F7 through FE must not appear in the sector length byte of the ID field.

In formatting the FD1771, only two requirements regarding GAP sizes must be met. GAP 2 (i.e., the gap between the ID field and data field) must be 17 bytes of which the last 6 bytes must be zero and that every address mark be preceded by at least one byte of zeros. However, it is recommended that every GAP be at least 17 bytes long with 6 bytes of zeros. The FD1771 does not require the index address mark (i.e., DATA = FC, CLK = D7) and need not be present.

References:

- 1) IBM Diskette OEM Information GA21-9190-1.
- 2) SA900 IBM Compatibility Reference Manual — Shugart Associates.

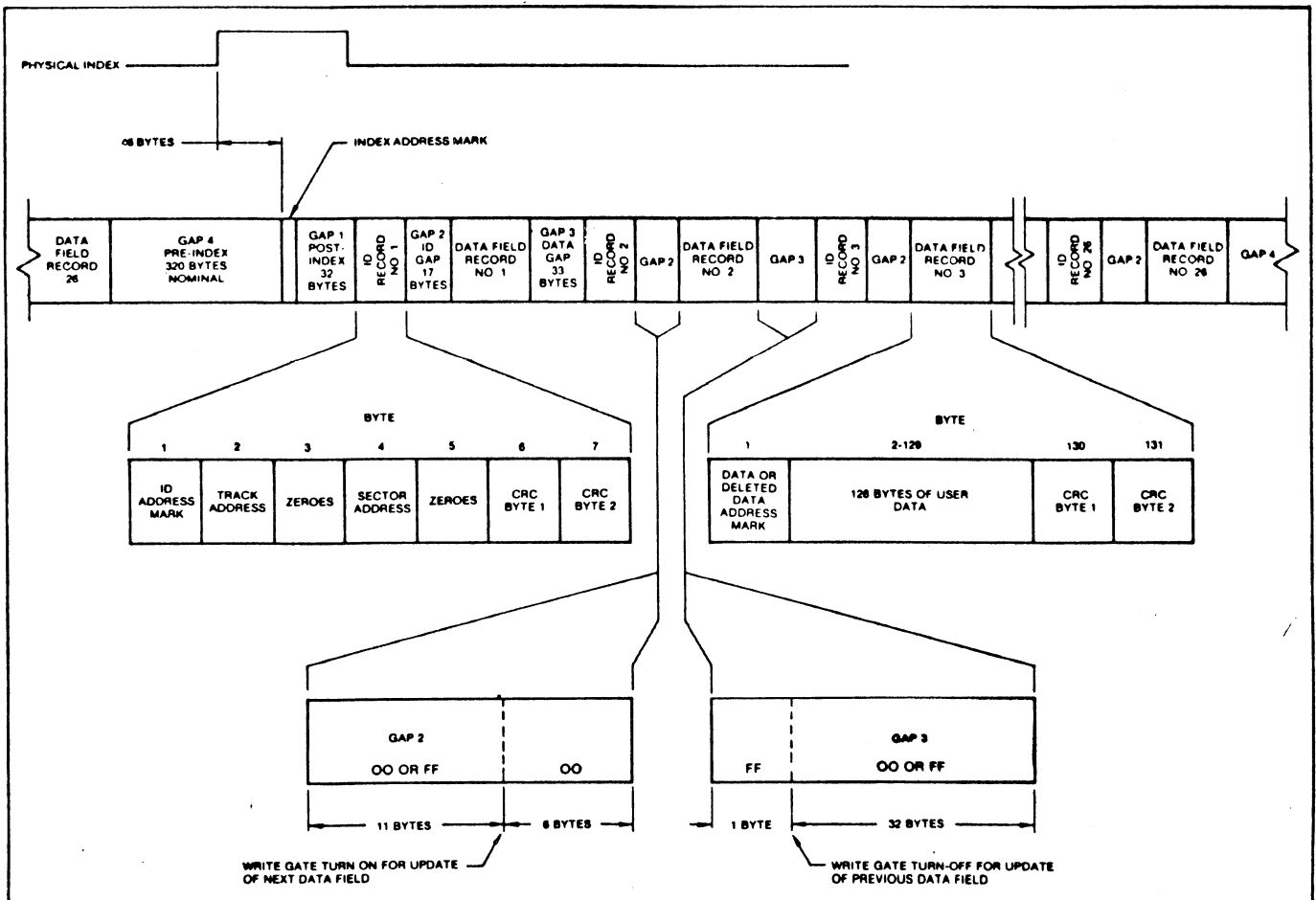

TRACK FORMAT

ELECTRICAL CHARACTERISTICS

Maximum Ratings

V _{DD} with respect to V _{BB} (Ground)	+20 to -0.3V
Max Voltage to any input with respect to V _{BB}	+20 to -0.3V
Operating Temperature	0°C to 70°C
Storage Temperature	-55°C to +125°C

OPERATING CHARACTERISTICS (DC)

T _A = 0°C to 70°C, V _{DD} = +12.0V ± .6V,
V _{BB} = -5.0 ± .5V, V _{SS} = 0V, V _{CC} = +5V ± .25V
I _{DD} = 10 ma Nominal, I _{CC} = 30 ma Nominal,
I _{BB} = 0.4 μa Nominal

Symbol	Characteristic	Min.	Typ.	Max.	Units	Conditions
I _{LI}	Input Leakage			10	μA	V _{IN} = V _{DD}
I _{LO}	Output Leakage			10	μA	V _{OUT} = V _{DD}
V _{IH}	Input High Voltage	2.6			V	
V _{IL}	Input Low Voltage (All Inputs)			0.8	V	
V _{OH}	Output High Voltage	2.8			V	I _O = -100 μA
V _{OL}	Output Low Voltage			0.45**	V	I _O = 1.0 mA

**Write Gate V_{OL} ≤ 0.5V.

TIMING CHARACTERISTICS

T _A = 0°C to 70°C, V _{DD} = +12V ± .6V,
V _{BB} = -5V ± .25V, V _{SS} = 0V, V _{CC} = +5V ± .25V

NOTE: Timings are given for 2 MHz Clock. For those timings noted, values will double when chip is operated at 1 MHz. Use 1 MHz when using mini-floppy.

Read Operations

Symbol	Characteristic	Min.	Typ.	Max.	Units	Conditions
TSET	Setup ADDR and CS to \overline{RE}	100			nsec	C _L = 25 pf
THLD	Hold ADDR and CS from \overline{RE}	10			nsec	
TRE	\overline{RE} Pulse Width	500			nsec	
TDRR	DRQ Reset from \overline{RE}			500	nsec	
TIRR	INTRQ Reset from \overline{RE}			3000	nsec	C _L = 25 pf
TDACC	Data Access from \overline{RE}			450	nsec	
TDOH	Data Hold from \overline{RE}	50		150	nsec	

Write Operations

Symbol	Characteristic	Min.	Typ.	Max.	Units	Conditions
TSET	Setup ADDR and CS to \overline{WE}	100			nsec	See Note
THLD	Hold ADDR and CS from \overline{WE}	10			nsec	
TWE	\overline{WE} Pulse Width	350			nsec	
TDRR	DRQ Reset from \overline{WE}			500	nsec	
TIRR	INTRQ Reset from \overline{WE}			3000	nsec	
TDS	Data Setup to \overline{WE}	250			nsec	
TDH	Data Hold from \overline{WE}	150			nsec	

External Data Separation ($\overline{XTDS} = 0$)

Symbol	Characteristic	Min.	Typ.	Max.	Units	Conditions
TPWX	Pulse Width Read Data & Read Clock	150		350	nsec	
TCX	Clock Cycle External	2500			nsec	
TDEX	Data to Clock	500			nsec	
TDDX	Data to Data Cycle	2500			nsec	

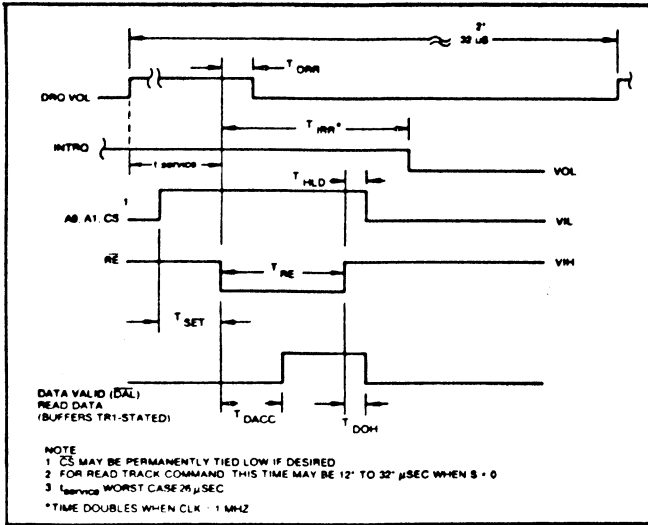

READ ENABLE TIMING

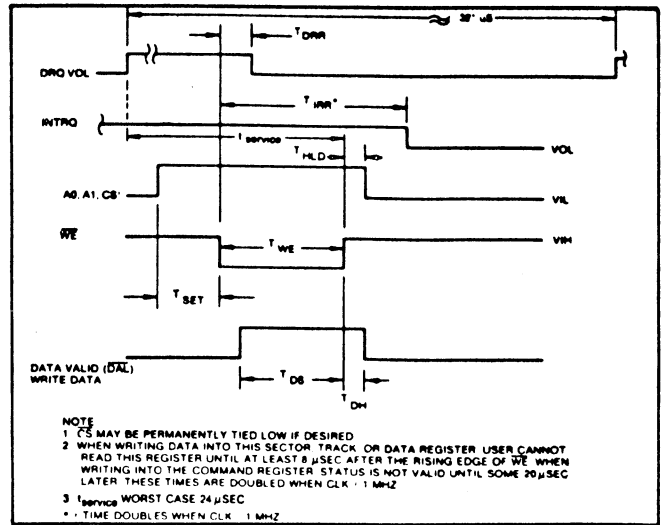

WRITE ENABLE TIMING

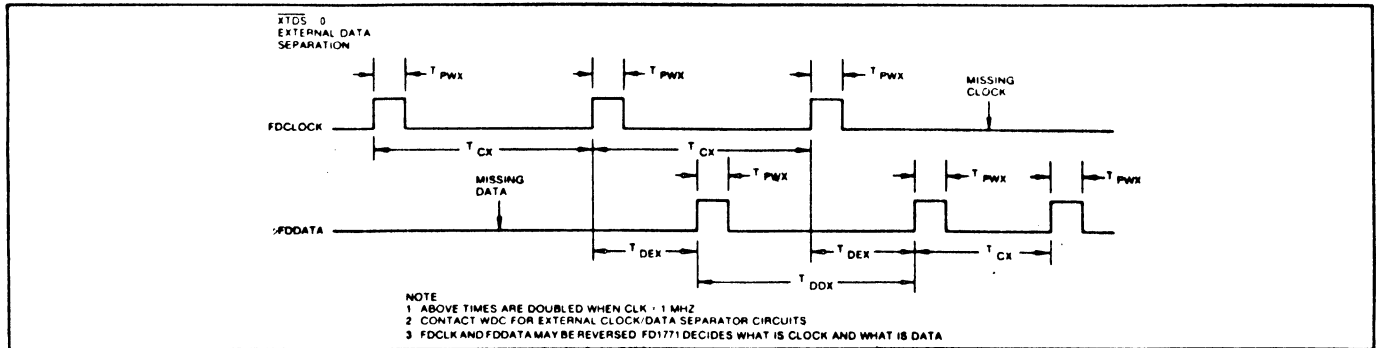

READ TIMING (XTDS = 0)

Internal Data Separation (XTDS = 1)

Symbol	Characteristic	Min.	Typ.	Max.	Units	Conditions
TPWI	Pulse Width Data and Clock	150		1000	nsec	
TCI	Clock Cycle Internal	3500		5000	nsec	

Write Data Timing

Symbol	Characteristic	Min.	Typ.	Max.	Units	Conditions
TWGD	Write Gate to Data		1200		nsec	300 nsec ± CLK tolerance
TPWW	Pulse Width Write Data	500		600	nsec	
TCDW	Clock to Data		2000		nsec	± CLK tolerance
TCW	Clock Cycle Write		4000		nsec	± CLK tolerance
TWGH	Write Gate Hold to Data	0		100	nsec	

Miscellaneous Timing

Symbol	Characteristic	Min.	Typ.	Max.	Units	Conditions
TCD ₁	Clock Duty	175			nsec	2 MHz ± 1% See Note These times doubled when CLK = 1 MHz
TCD ₂	Clock Duty	210			nsec	
TSTP	Step Pulse Output	3800		4200	nsec	
TDIR	Direct Setup to Step	24			usec	
TMR	Master Reset Pulse Width	10			usec	
TIP	Index Pulse Width	10			usec	
TWF	Write Fault Pulse Width	10			usec	

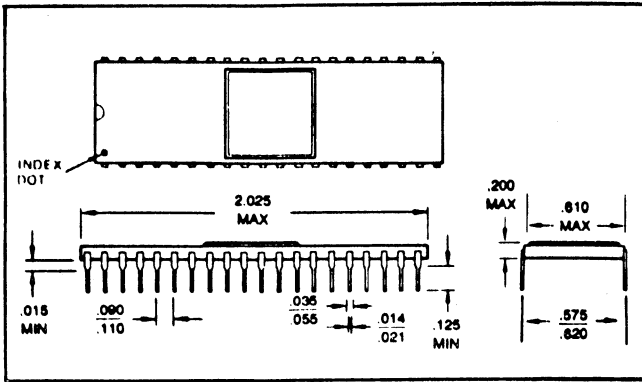

FD1771A CERAMIC PACKAGE

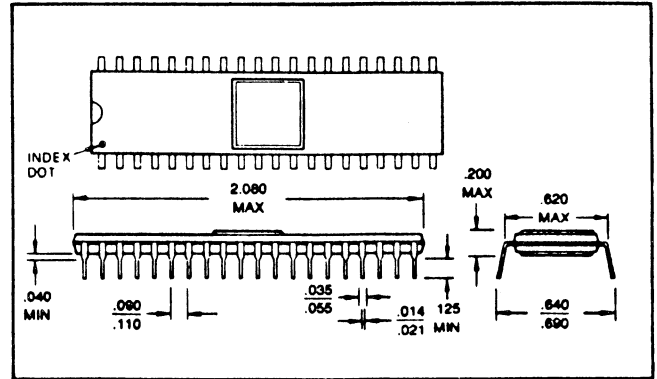

FD1771B PLASTIC PACKAGE

This is a preliminary specification with tentative device parameters and may be subject to change after final product characterization is completed.

Information furnished by Western Digital Corporation is believed to be accurate and reliable. However, no responsibility is assumed by Western Digital Corporation for its use; nor any infringements of patents or other rights of third parties which may result from its use. No license is granted by implication or otherwise under any patent or patent rights of Western Digital Corporation. Western Digital Corporation reserves the right to change said circuitry at any time without notice.

WESTERN DIGITAL
CORPORATION

3128 REDHILL AVENUE, BOX 2180
NEWPORT BEACH, CA 92663 (714) 557-3550, TWX 910-595-1139